

Primer Feed Hardware List

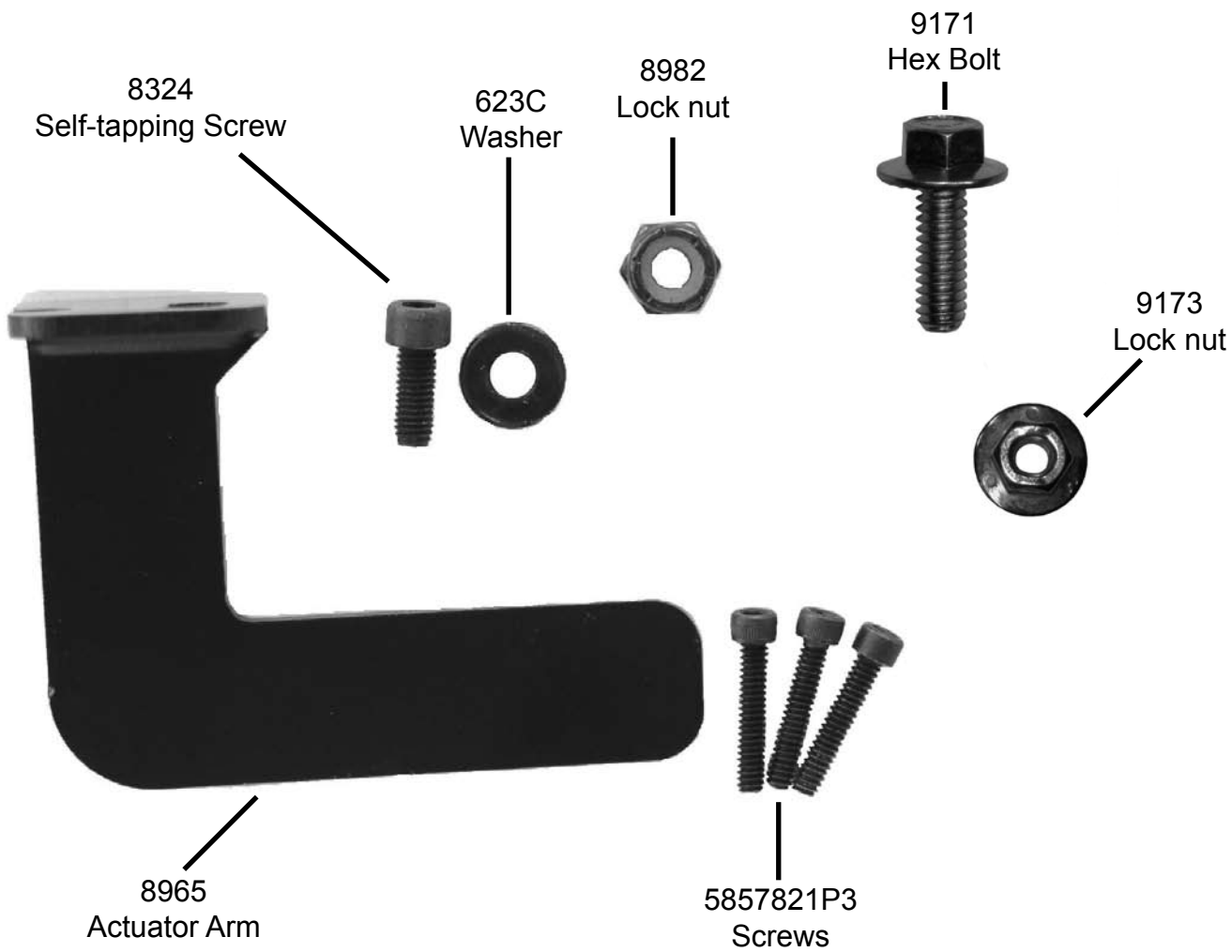

Large Capacity Progressive Primer Feed

For 650, 76 Series, 8567 Grabber, and 9000 Series

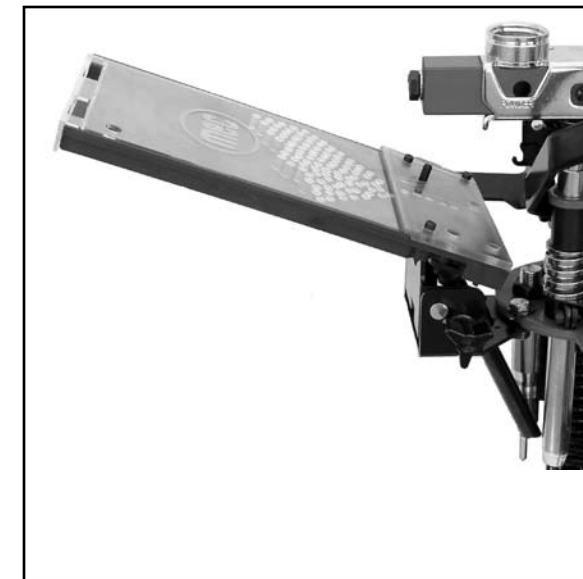

Note: You may need to occasionally clean or polish the tray to make the primers slide properly. We recommend using either a silicone cloth or furniture polish. If over time you notice that the operation of the tray is not smooth anymore, you may need to clean off all of the sliding components. You can remove the small cover over the slide and pusher by taking out the three screws that are retained with nuts from the backside. Caution: When removing the cover, make sure that you do not loose the spring that operates the primer feed slide. Wipe off all of the components and tray using a mild cleaner and reassemble.

- **Holds 200+ Primers**
- **Tray pivots flat for easy filling**
- **Self-lubricating plastic tray**
- **User-Friendly!**



MAYVILLE ENGINEERING COMPANY, INC.

An Employee Owned Company

800 Horicon Street, Suite 1 • Mayville, Wisconsin 53050 (920) 387-4500 Fax (920) 387-5802

Website: www.mecreloaders.com • E-mail: sales@mecreloaders.com



MEC 8983 Primer Feed Installation Instructions

TOOLS REQUIRED: (1) 7/16" wrench, (1) 3/8" wrench, 5/32" Allen wrench, 7/64" Allen wrench

- 1) If you have purchased a reloader that already has the new mounting bracket installed, skip to instruction #7.
- 2) Before starting the installation of your new primer feed, it is recommended that you empty the carrier of all shells and tip the measure back out of the way.
- 3) Remove current primer feed and clamp assembly.

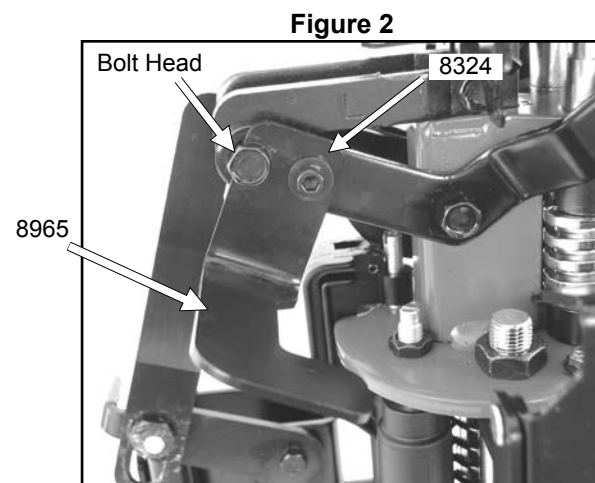
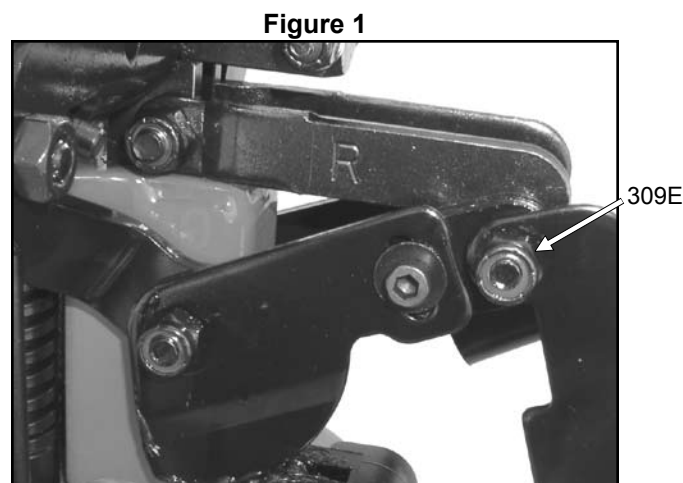

4) Remove lock nut (309E) from link bolt (Figure 1) and start shorter lock nut (8982) do not tighten yet. Slide this bolt to the left about 1/4" and slide the slot of actuator arm (8965) between the head of the bolt and link (Figure 2). Align the slot of the actuator arm with the hole in handle or hydraulic link strap, using 5/32 allen wrench, attach with (623C) washer and self-tapping screw (8324). Tighten actuator arm down about in the middle of the slot being careful not to over tighten. Now tighten the (8982) lock nut on the link bolt and back off 1/4 turn to allow the links to pivot. Note: On hydraulically operated machines, depress the pedal to make sure that the actuator arm (8965) does not contact the truss rod when the machine is in the down position. If it does, loosen the bolt that attaches the truss rod to the base and move it in slightly towards the machine and retighten.

Figure 4

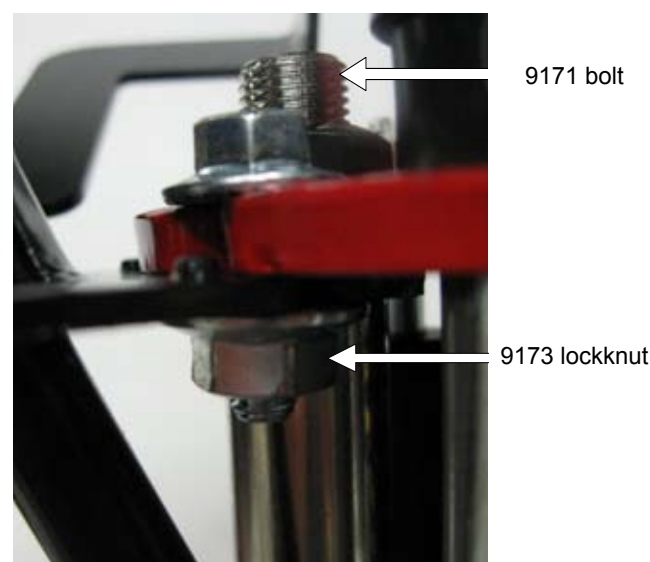

- 5) Install hardware to mounting bracket as shown (Figure 3 & 4). Hex bolt (9171), nut (9173) below.
- 6) Slide the mounting bracket under the turret frame with the bolt going into the slot of the turret. The head of the bolt should be above the turret frame as shown in (Figure 4). Align the bracket so that the two locating nubs on the bracket are 1/32"-1/16" from the turret (Figure 5) and that it is also parallel with the base (Figure 6). While holding the bracket in position, snug the bolt up slightly. Depress the handle on manual machines or pedal on hydraulic units to check for alignment of tube with hole in shell carrier. Tube should be centered between the deprime punch and reprime tube. When properly aligned, tighten the nut using 7/16 wrench while holding the bolt with 3/8 wrench and re-check alignment.

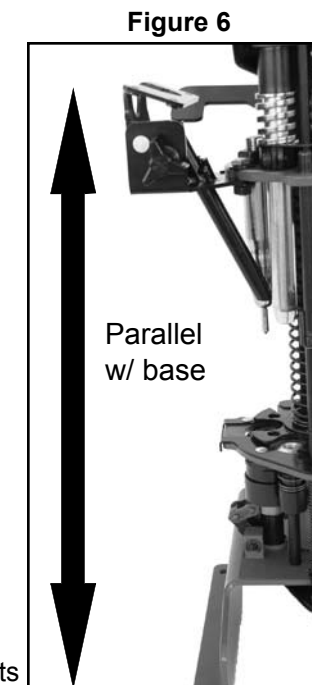
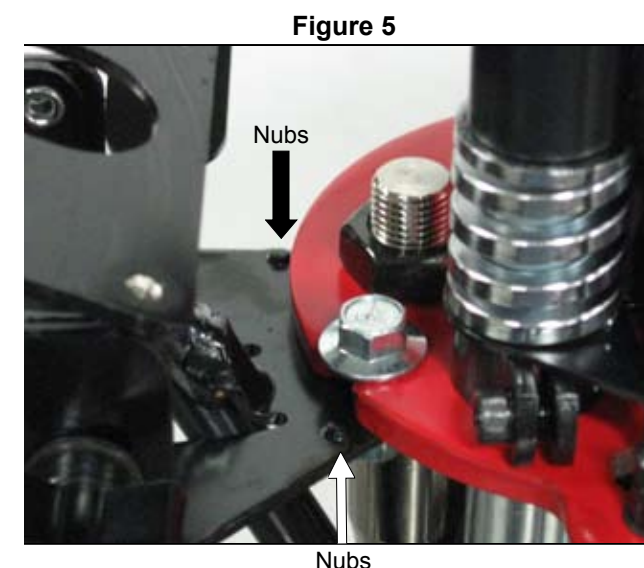

- 7) Mount primer tray to bracket using the three #6 - 32 x 0.75 long screws (5857821P3) provided. Tighten screws using 7/64 allen wrench.
- 8) Loosen the thumbscrew on the mounting bracket and pivot primer tray down to its level position (Figure 7). Remove primer feed cover from tray by sliding it back, then lifting it off. Position box of primers face down on tray, slide box cover out and lift off the liner. You can now add another box of primers. Replace cover on tray and slide forward until it locks into position. Pivot the primer feed up until the tray spout fully enters the funnel of the drop tube and tighten the thumbscrew. As you tip up the tray, primer should fill up the slot leading into the slide that drops the primers. If the slot is not full, slide the primer pusher back and forth a couple of times (Figure 8).
- 9) Depress handle or pedal to check for proper primer drop. Actuator arm (8965) should contact about 1/2 of primer tray slide (Figure 8), if it doesn't; the bracket is not parallel to the base. Loosen the bracket and readjust as per instruction #6. You can adjust when a primer drops by adjusting the actuator arm forward or backward. If primer drops late, loosen the self-tapping screw in actuator arm and move toward you as shown by the arrow in (Figure 8). If the primer drops too soon, loosen self-tapping screw in actuator arm and move slightly away from you.
- 10) If at any time you wish to stop the feeding of primers, simply loosen the thumbscrew and pivot tray back to its level position. You can now lower the machine and no primers will be dispersed.

